



**YEAR 11**

**CHEMISTRY**

**MODULE 1**

**LESSON SIX**



# THEORY

## Types of Bonding

- 1.4.5 Explore the similarities and differences between the nature of intermolecular and intramolecular bonds and the strength of the forces associated with each, in order to explain the:
- physical properties of elements
  - physical properties of compounds

### INTRAMOLECULAR BONDS

As the name suggests, **intramolecular** bonds exist **within** molecules and include:

- .....
- .....
- .....

Recall from Lesson 2, that **covalent** and **ionic** bonds exist on a spectrum based on the difference of **electronegativities** between atoms participating in the bond.



Metallic bonds will be explored within this lesson.

See the types of intramolecular bonds listed below, in order of strength:

*covalent bonds > ionic bonds > metallic bonds*

# THEORY

## INTERMOLECULAR FORCES

As the name suggests, intermolecular forces exist **between** molecules and include:

- .....
- .....
- .....

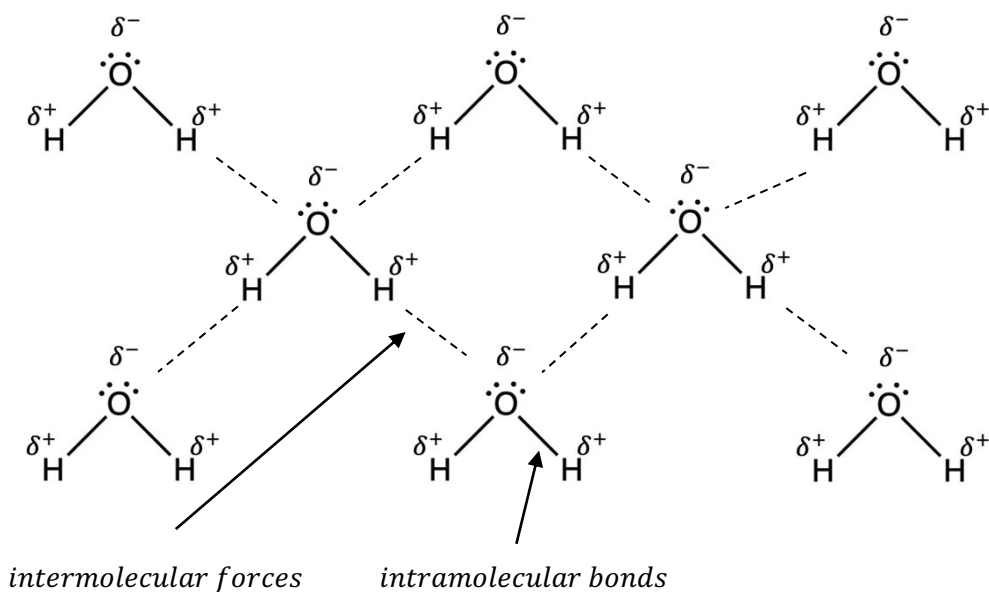

## Dipole-Dipole Forces

For example, HBr:

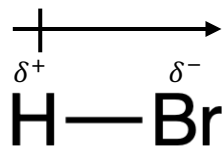

As Bromine is much more electronegative than the Hydrogen atom, there is an asymmetric distribution of charge and as such, a **net dipole**. The **dipole moment** of the molecule is shown by the arrow.

This dipole moment allows polar covalent molecules such as HBr to experience electrostatic attractions with other molecules.

# THEORY

See the diagram below:

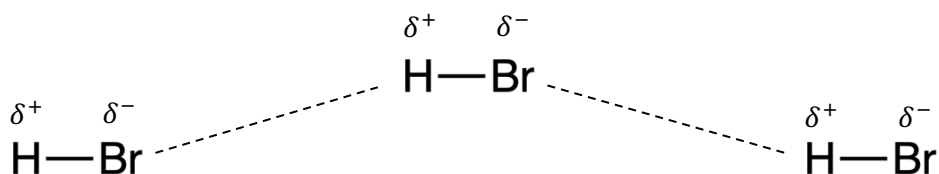

The strength of dipole-dipole forces is proportionate to the **magnitude** of the **dipole moment** of the bonds in the molecules.

.....

.....

Recall that the dipole moment refers to the extent of charge separation (or asymmetry of charge) and this is greater in molecules with a greater difference in electronegativity.

For example, HCl is more polar than HBr as there is a greater **difference** in **electronegativity** between Hydrogen and Chlorine than there is between Hydrogen and Bromine. This is because Chlorine is more electronegative than Bromine.

## Hydrogen Bonding

.....

.....

.....

.....

This is due to the fact that F, O, N atoms are **small** and **highly electronegative**, and when paired with an atom with a very **low electronegativity** such as Hydrogen, a very **large dipole moment** forms.

Consequently, the intermolecular interactions formed by molecules with such bonds, Hydrogen bonds, are so strong that they are in a category of their own. Most Hydrogen bonds are about ten times the strength of a dipole-dipole force.

It is most correct to draw Hydrogen bonds between the partially positive hydrogen atom and a **lone pair** in the N, O or F atom.

# THEORY

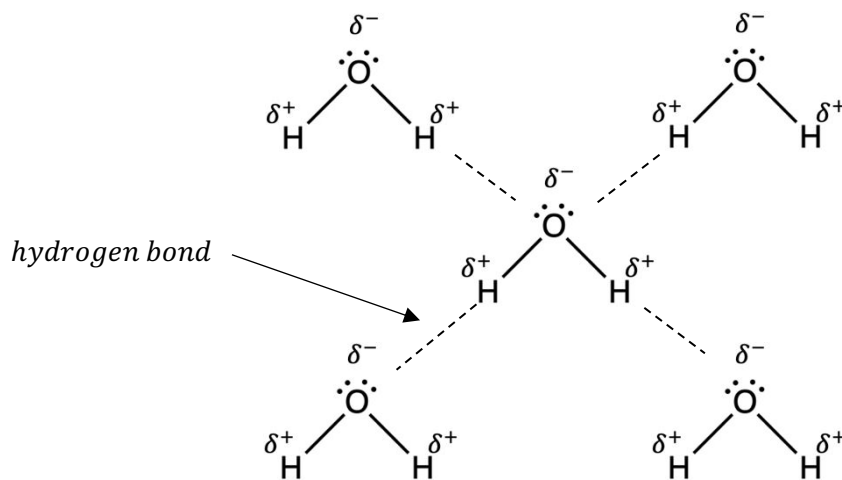

## Dispersion Forces

They arise because of temporary dipoles formed by the continuous random movement of electrons around an atom.

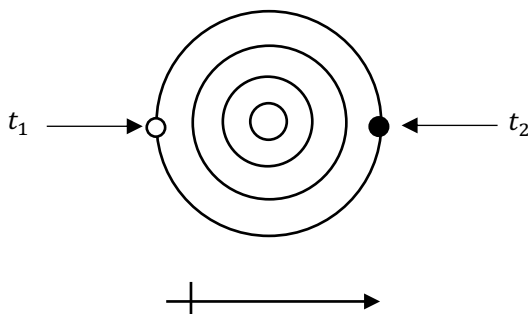

There are *many electrons* in an atom and all of them move in many directions. As such, many temporary dipoles are forming and breaking every instant.

The sum of all such dipole moments at any one instant may form one overall dipole moment. This overall dipole is typically very small in magnitude, meaning that the strength of this intermolecular force is quite weak. In fact, dispersion forces are the weakest intermolecular force.

See the types of intermolecular forces listed below, in order of strength:

*hydrogen bonds > dipole-dipole forces > dispersion forces*

.....

.....

.....

# THEORY

Ultimately this is because dispersion forces are produced by the random movement of electrons, and all types of molecules have electrons.

---

This is because heavier molecules have more atoms, which in turn means that they have more electrons which can form temporary dipoles and the likelihood of having a greater net dipole increases.

Note that it is not just diatomic molecules that are non-polar. You may see certain molecules which contain polar bonds, but no net dipole. This is often due to the fact that the molecules are symmetrical, and their dipoles all cancel each other out.

See for example, carbon dioxide which is a linear molecule with polar C=O bonds.

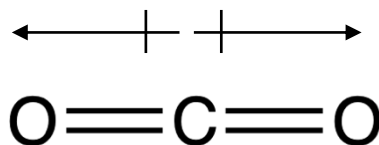

In addition, methane with polar C-H bonds, has no overall dipole either:

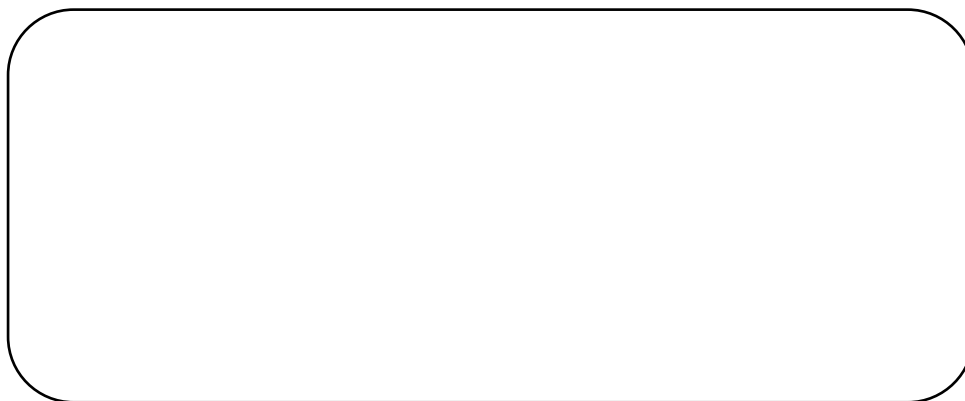

This is not to say all tetrahedral molecules are non-polar however, as **chloromethane** does have a net dipole:



# THEORY

## COMPARING INTRAMOLECULAR BONDS AND INTERMOLECULAR FORCES

Note that intramolecular *bonds* exist between atoms within a molecule whilst intermolecular *forces* are merely **electrostatic attractions** between molecules.

As such, intramolecular bonds are, much stronger than intermolecular forces.

*covalent bonds > ionic bonds > metallic bonds > hydrogen bonds > dipole-dipole forces > dispersion forces*

Note that whilst **Hydrogen bonds** are approximately 10 times stronger than **dipole-dipole** forces, they are about one tenth as strong as **covalent** or **ionic** bonds.

## RELATIONSHIP BETWEEN INTERMOLECULAR FORCES AND MELTING/BOILING POINT

Recall the particle model of matter:

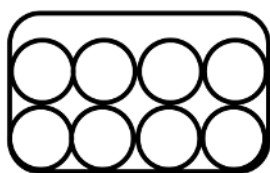

*solids*

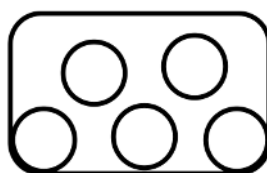

*liquids*

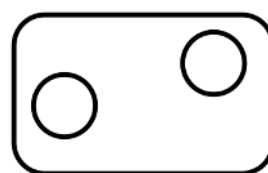

*gases*

In changing phase from solid → liquid → gas, it is the **intermolecular forces** that must be weakened. Thus, molecules which experience stronger **intermolecular forces** require more energy to change phase.

We can use this to understand the following melting and boiling points:

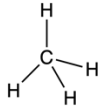
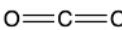
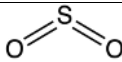
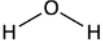
Molecule	Structure	Polarity	Melting point (°C)	Boiling point (°C)
methane		non-polar	-182.5	-162
carbon dioxide		non-polar	-78.5	-56.6
sulfur dioxide		polar	-72.7	-10
water		polar	0	100

# THEORY

## 1.4.4 Investigate the different chemical structures of atoms and elements, including but not limited to: metallic structure, covalent molecular, ionic networks, covalent networks (including diamond and silicon dioxide)

There are four main **categories** of chemical substances:

- Metals
- Ionic networks
- Covalent molecular substances
- Covalent networks

Studying the structure of each of these substances helps to understand the diverse properties that exist between them.

### METALLIC STRUCTURE

Metals are **three-dimensional repeating lattices** of positively charged ions (cations) which are surrounded by a **sea of delocalised electrons**.

The **formula unit** of a metallic lattice can be represented by the diagram below:

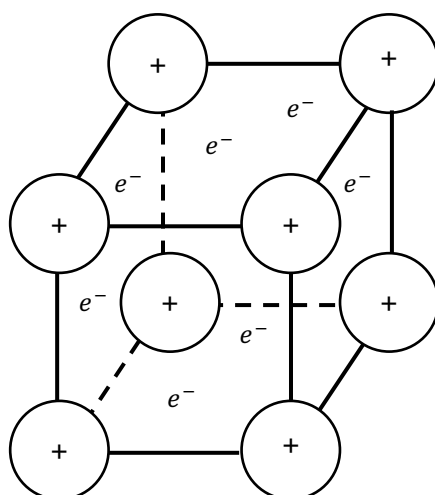

Metallic bonding is a very strong force of electrostatic attraction between positive cations and the sea of delocalised electrons.

This explains the relatively **high melting and boiling points** of metals. For example, the boiling point of Sodium is 882°C.

Metals are **good conductors** of **electricity** due to the sea of delocalised electrons which are **mobile** and can move and carry charge.

# THEORY

Metals are also **good conductors** of **heat**. Heating a metal, the energises both delocalised electrons and cations of the lattice so that they vibrate more rapidly. This increases the likelihood of **collisions** between them, allowing for the transfer and conduction of energy.

Metals are **malleable**. When a force causes a layer of ions can slide over another, the delocalised electrons maintain the attraction between the layers.



Metals are **lustrous** as the sea of delocalised electrons is able to absorb and re-emit photons of light.

Metals often have **high densities** as particles are packed closely together in its three-dimensional repeating lattice.

There are limitations to this model however and these include the inability to explain:

- The range in melting and boiling points
- The differences in electrical conductivity
- The magnetic nature of some metals

## IONIC NETWORKS

Ionic substances also exist in **three-dimensional repeating lattices** of cations and anions. Its **formula unit** may similarly be represented below:

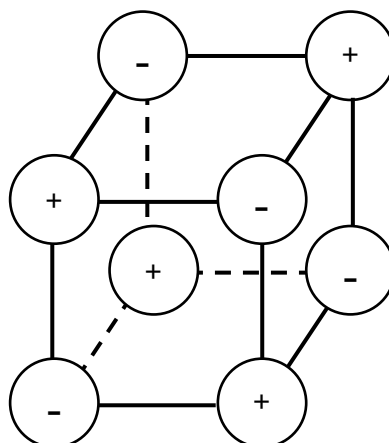

# THEORY

Ionic networks have **high melting and boiling points** as ionic bonding is quite strong. Sodium chloride has a boiling point of 1413°C.

Ionic networks are **poor conductors of electricity** in the **solid state** as there are no mobile charge carriers.

However, they are **good conductors of electricity** in the **molten** and **aqueous states** as ions are mobile charge carriers. Similarly, they are **poor conductors of heat** in the **solid state** but good conductors in the **molten** and **aqueous states** where there are mobile charge carriers.

Ionic substances are often hard due to the high strength of ionic bonds.

However, they are often **brittle** due to their structure and not malleable like metals which have a sea of delocalised electrons.



## COVALENT MOLECULAR STRUCTURE

On the other hand, covalent molecular substances are NOT lattices but rather consist of discrete molecules between which intermolecular forces exist.

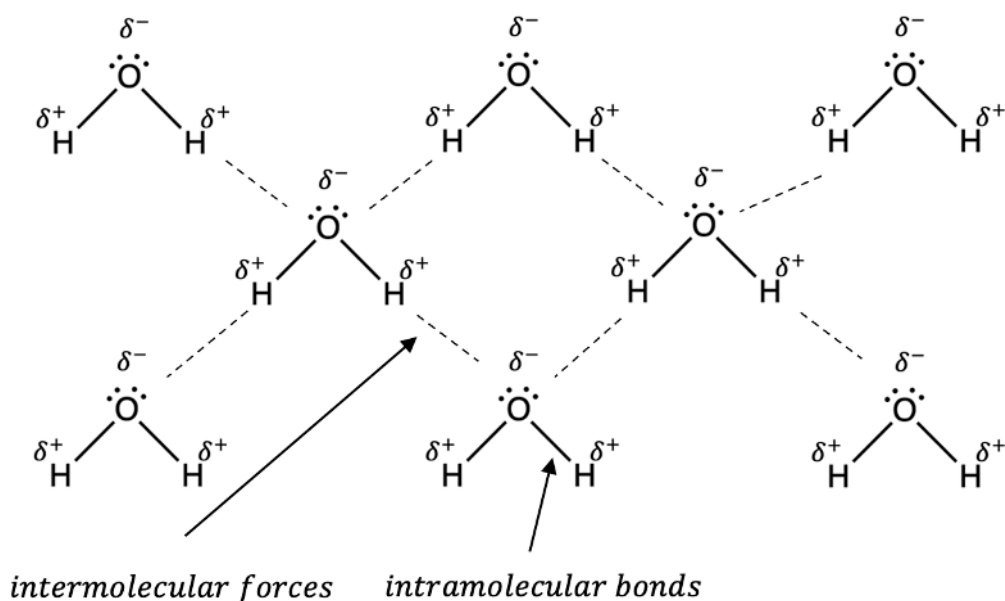

# THEORY

To melt or boil covalent molecular substances, it is these intermolecular forces which must be overcome. This contrasts with ionic and metallic networks where ionic and metallic bonds needed to break, to facilitate a change in phase.

As intermolecular *forces* are on a whole, much weaker than intramolecular *bonds*, the **melting and boiling points** are quite **low** in comparison. For example, the boiling point of ammonia is  $-33^{\circ}\text{C}$ , carbon dioxide is  $-56.6^{\circ}\text{C}$  and water is  $100^{\circ}\text{C}$ .

Covalent molecular substances are **poor conductors** of both **heat** and **electricity** as there are no mobile charge carriers. They are often **soft** in the solid state because intermolecular forces are quite weak. In the solid state, they are also quite **brittle**.

## COVALENT NETWORKS

While most covalent substances exist as individual molecules as do covalent molecular substances, some exist in **continuous three-dimensional structures** called **covalent networks**. Examples include diamond and silicon dioxide.

**Diamond** is a repeating lattice of carbon atoms arranged tetrahedrally as shown below:

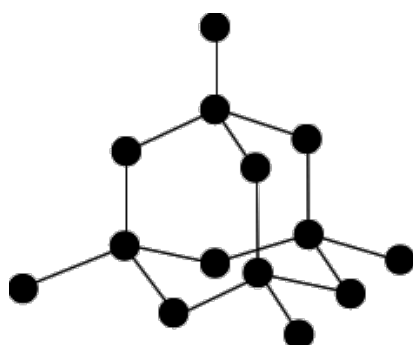

**Silicon dioxide** ( $\text{SiO}_2$ ) is also arranged roughly tetrahedrally as shown below:

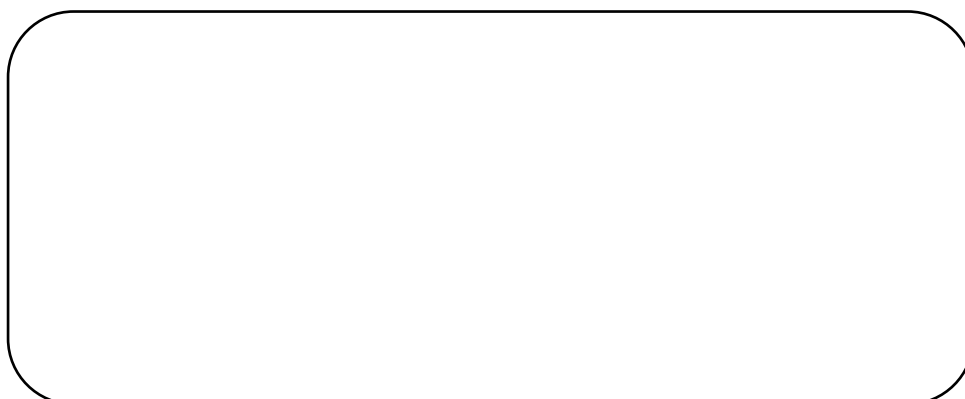

Silicon dioxide is the main component of glass.

# THEORY

Covalent networks have **very high melting and boiling points** as covalent bonds are very strong (strongest intramolecular bond). Boiling points of silicon dioxide and diamond are 2230°C and 4830°C respectively

For the same reasons, **covalent networks** are very **hard**. Diamond is the hardest known substance in the world. They are, however, brittle

Covalent networks generally **do not conduct electricity** as there are no mobile charge carriers.

However, covalent networks may have moderate to high thermal conductivity, the reasons for which differ based on the covalent network in concern.

Diamond will be explored in more detail below.

## 1.4.3 Investigate elements that possess the physical property of allotropy

.....  
.....

It might come at quite a shock that **diamond**, which is shiny and extremely hard, is made of the same element as **graphite**, which is dull, soft, and slippery. In fact, diamond and graphite are made entirely of carbon atoms only. The difference in their properties arises from their unique structures.

That is, the same element is arranged structurally differently, and this gives rise to a different set of physical properties. This is **allotropy**.

Examples of elements which display allotropy include:

- Carbon
- Phosphorous
- Sulfur
- Tin
- Oxygen

Below we will explore the properties of the allotropes of Carbon.

# THEORY

## DIAMOND

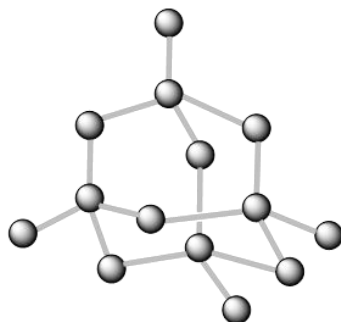

As aforementioned, diamond consists of a repeating lattice of tetrahedrally arranged carbon atoms which are joined by covalent bonding.

The high strength of the covalent bonding gives rise to very **high melting and boiling points** as well as making the substance extremely hard. Diamond has a boiling point of 4830°C and is the hardest substance on Earth.

The lack of delocalised electrons means that diamond does not conduct electricity.

## GRAPHITE

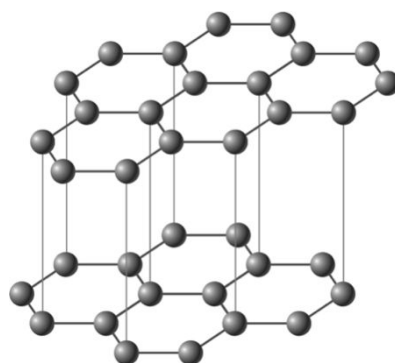

Graphite is a **covalent network** consisting of layers of planar 'carbon sheets' of hexagonal rings of carbon atoms. **Dispersion forces** serve to weakly attract the layers or 'sheets'. In this structure, carbon atoms are bonded to three other carbon atoms.

Given that carbon can form up to four bonds, there is a delocalised electron which makes graphite a **good conductor of electricity** and viable for use in applications where metals are undesirable (e.g. car battery electrodes). Graphite electrodes have higher chemical stability and thermal resistivity compared to standard metal electrodes.

The strong covalent bonds within the layers of carbon sheets guarantees a high resistance to heat and gives it a **high melting and boiling point**.

Despite this, the weak dispersion forces allow for the layers to easily **slide** or '**slip**' over each other which makes graphite suitable for use as a **lubricant**. Graphite is often used as an industrial lubricant to reduce the friction in moving parts such as locks or other machinery. This slipperiness also explains graphite's use in lead pencils.

# THEORY

## BUCKMINSTERFULLERENE ('BUCKY BALLS')

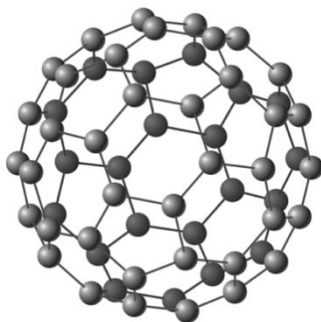

Fullerenes are a subset of carbon allotropes known as **nanomaterials** which are 1-100nm wide.

Fullerenes have a roughly **spherical** shape with carbon atoms arranged in a series of **hexagonal** and **pentagonal** rings. The structure roughly resembles a soccer ball.



The most stable fullerene is known as buckminsterfullerene and has a molecular formula of  $C_{60}$ . There is a high degree of symmetry within the structure of a 'bucky ball' explaining its non-polar covalent nature. As such it only experiences weak dispersion forces and has a **relatively low melting and boiling point**. Buckminsterfullerenes sublime at 800K.

Fullerenes make covalent bonds to three other carbon atoms, leaving a delocalised electron which is free to move and **conduct electricity**.

These unique properties have allowed for their use in **flexible solar panels** as whilst they are electrically conductive, their relatively weak intermolecular forces have allowed for their flexibility. This provides a significant advantage over traditional solar panels which are made of **rigid silicon crystals** and could not be placed atop caravan roofs or the cabin of a boat which may be curved.

# THEORY

## CARBON NANOTUBES

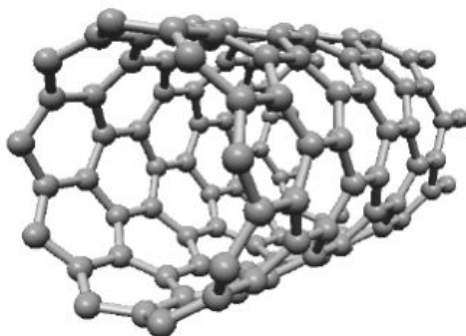

Nanotubes also fall under the category of nanoparticles and are a relatively recent innovation.

Carbon atoms form three bonds, leaving a delocalised electron free to move and **conduct electricity**. They are also thermally conductive and very uniquely **strong**. The reasons for their thermal conductivity are beyond the scope of this course.

It has been said that nanotubes are **stronger** than **steel** whilst also being **moderately flexible** and this is attributed to the strong carbon-carbon covalent bonds as well as its structure as a 2D matrix rolled into cylinders which allows it to deform slightly.

The same cannot be said for diamond which is an extensive 3D lattice which would not deform but rather break (and is therefore brittle).

## OTHER ELEMENTS DISPLAYING ALLOTROPY

**Oxygen** also displays allotropy. Apart from the standard  $O_2$  we all breathe,  $O_3$  is known as ozone and is present in our upper atmosphere tasked with filtering harmful UV rays.  $O_4$ , also known as tetraoxygen is red in colour.

**Sulfur** also shows allotropy. Several allotropes exist:  $S_2$ ,  $S_3$ ,  $S_5$ ,  $S_7$ ,  $S_8$ . Of these, the most important forms are:

- Rhombic
- Monoclinic
- Plastic

Both rhombic and monoclinic sulfur forms  $S_8$  molecules which are essentially puckered rings:

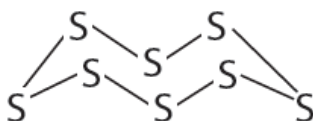

# THEORY

Plastic sulfur consists of long chains of sulfur atoms singly bonded to one another and has a rubbery texture:

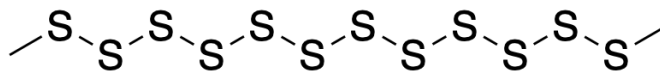

**Phosphorous** has several allotropes. White phosphorous is a covalent molecule of 4 phosphorous atoms. Black phosphorous is the most stable form and consists of buckled layers of phosphorous atoms where each P atom is bonded to three others. Weak dispersion forces exist between the sheets. Red phosphorous consists of a chain of  $P_4$  units.



White

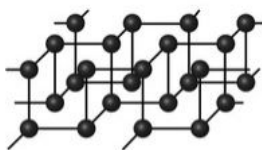

Black

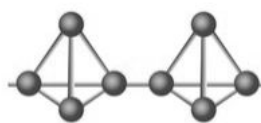

Red

# PRACTICE QUESTIONS

- 1. Which of the following atoms when bonded to the hydrogen atom do NOT allow for hydrogen bonding to occur?**
  - a. Fluorine
  - b. Chlorine
  - c. Oxygen
  - d. Nitrogen
  
- 2. Identify the set that correctly arranges the electrical conductivity of the structures from lowest to highest.**
  - a. Metallic, ionic, covalent network
  - b. Metallic, ionic, covalent molecular
  - c. Covalent network, ionic, metallic
  - d. Ionic, covalent molecular, metallic
  
- 3. Which of the following statement regarding allotropes is incorrect?**
  - a. Diamond and graphite are allotropes of carbon
  - b. Allotropes display different physical properties
  - c. Sulfur has more than two different allotropes
  - d. Allotropes are made of the same element regardless of state
  
- 4. Which of the following explains why graphite can conduct electricity?**
  - a. Graphite has a metallic structure and therefore has a sea of delocalised electrons that can carry charge
  - b. Graphite's structure has each carbon bonded to three others, leaving the fourth electron free to act as a mobile charge
  - c. Graphite conducts electricity only when in molten and aqueous states due to electrons now being free to act as mobile charges
  - d. Graphite is a metalloid and therefore is able to display the metallic property of electrical conductivity
  
- 5. Ionic networks change phase through the weakening of:**
  - a. Intramolecular bonds
  - b. Intermolecular forces
  - c. Ionic bonds
  - d. Covalent bonds

# PRACTICE QUESTIONS

6. Classify the bonding in each of the following molecules as metallic, ionic, polar covalent or non-polar covalent.

(1 mark each)

a.  $AgCl$

.....

b.  $HCl$

.....

c.  $CaCO_3$

.....

d.  $Na$

.....

e.  $KCl$

.....

f.  $H_2O$

.....

g.  $CO_2$

.....

7. Metals are highly prevalent in modern society and are present in a variety of shapes suited to different purposes. Identify and explain this property of metals which allows for this use with detailed reference to its chemical structure.



(3 marks)

.....  
.....  
.....  
.....  
.....

# PRACTICE QUESTIONS

8. Explain the differences in melting and boiling point of the substances below, in terms of their intramolecular bond and intermolecular forces.

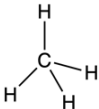
(6 marks)

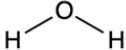
	Methane	Ammonia	Water
Structure			
Melting point (°C)	-182.5	-77.73	0
Boiling point (°C)	-162	-33.34	100

.....

.....

.....

.....

.....

.....

.....

.....

.....

.....

.....

.....

.....

.....

.....

.....

.....

.....

.....

.....

.....

.....

.....

# HOMEWORK

1. The following questions refer to the allotropes of carbon: diamond, graphite, and buckminsterfullerene.

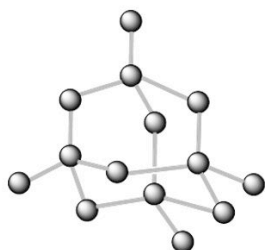

*diamond*

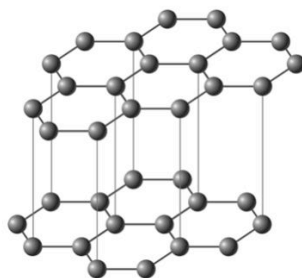

*graphite*

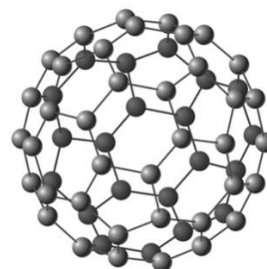

*buckminsterfullerene*

a. Explain what is meant by the term “allotrope”.

(2 marks)

.....

.....

.....

b. Explain the properties and uses of graphite.

(4 marks)

.....

.....

.....

.....

.....

.....

.....

.....

c. Explain why diamond is often referred to as the “hardest material in the world”.

(3 marks)

.....

.....

.....

.....

# HOMEWORK

2. With reference to either metallic, ionic, or covalent networks, assess the usefulness of a model you have learnt.

(4 marks)

.....

.....

.....

.....

.....

.....

.....

.....

3. Distinguish between intramolecular and intermolecular bonding with reference to a relevant example.

(2 marks)

.....

.....

.....

4. Harry was investigating the causes behind certain types of intermolecular bonding and concludes that:

*“Dispersion forces are caused by the rapid motion of subatomic particles around an atom while dipole-dipole forces are much stronger and are resultant from dipole moments caused by the polarity of molecules with hydrogen bonding being no different.”*

Evaluate the accuracy of Harry's statement.

(4 marks)

.....

.....

.....

.....

.....

.....

.....

.....

# HOMEWORK

5. Explain the difference in melting and boiling point between:

a. Covalent molecular and ionic substances

(3 marks)

.....

.....

.....

.....

.....

.....

b. Covalent molecular and covalent network substances

(3 marks)

.....

.....

.....

.....

.....

.....

6. Compare the electrical conductivity of sodium metal and sodium chloride salt.

(4 marks)

.....

.....

.....

.....

.....

.....

# HW ANSWERS

## Module 1 Lesson 5

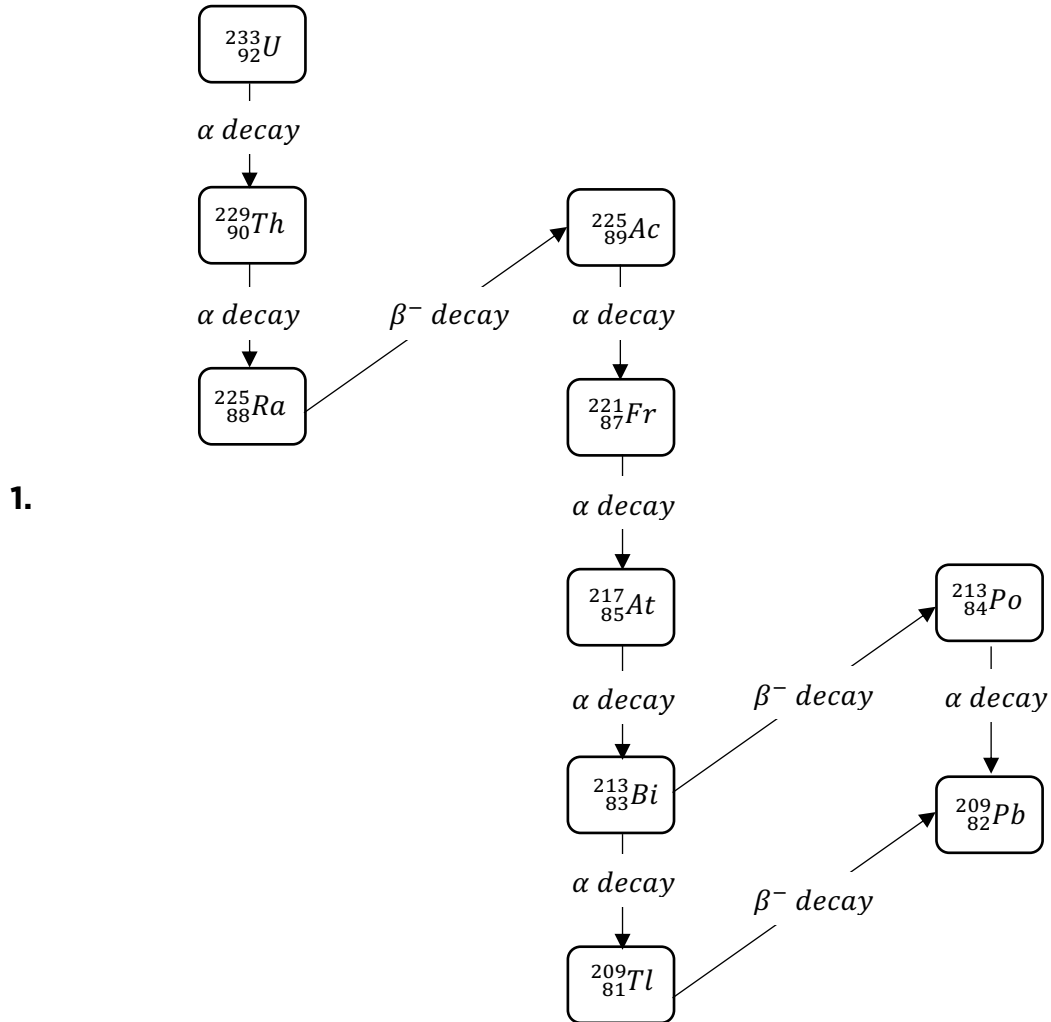

2a.

1

Explains that the half-life of a radioisotope refers to the time taken for exactly half of an initial radioactive nuclei to decay

# HW ANSWERS

**b.**

1	Determines the mass of iodine-131 required to withstand the heist period $\frac{14}{8} = 1.75$ $x(0.5)^{1.75} = 5$ $x = 16.8179 \dots g$
1	Determines the mass of phosphorous-33 required to withstand the heist period $\frac{14}{25.4} = 0.55118 \dots$ $x(0.5)^{0.55118 \dots} = 5$ $x = 7.326 \dots g$
1	Determines price of both isotopes Iodine-131 $\rightarrow 16.8179 \dots \times 90 = \$1513.61 \dots$ Phosphorus-33 $\rightarrow 7.326 \dots \times 150 = \$1098.96 \dots$
1	Identifies that phosphorus-33 is the most cost-effective way Gru can protect his invention

**c.**

1	Identifies phosphorous-33 undergoes $\beta^-$ —decay as it has 15 protons and 17 neutrons and thus undergoes
1	Identifies that $\beta$ radiation has moderate penetrating ability and can be stopped with an aluminium sheet
1	Explains Vector can protect his health and go through with the heist by wearing an aluminium suit

**3.**

1	Identifies the use of an isotope in industry <ul style="list-style-type: none"> <li>• Strontium-90 is often used in industry to monitor the thickness of metal sheets</li> <li>• Technetium-99m is often used in medical diagnostic imaging</li> </ul>
1	Explains in detail how the isotope is used in industry <ul style="list-style-type: none"> <li>• Strontium-90 decays via emission of a beta-minus particle where the intensity of the radiation detected at the detector varies inversely with the thickness of the metal being measured             <ul style="list-style-type: none"> <li>○ If the radiation intensity is much higher than expected, the metal is too thin</li> <li>○ If the radiation intensity is much lower than expected, the metal is too thick</li> </ul> </li> <li>• Technetium has multiple oxidation states and can be attached to molecules which have a natural affinity to specific organs and tissues, allowing for detailed localised imaging</li> </ul>
1	Provides details regarding the isotope's half-life or properties that make it suitable for industrial use <ul style="list-style-type: none"> <li>• Strontium-90             <ul style="list-style-type: none"> <li>○ Emission of beta particles is desirable as alpha particles provides insufficient penetration while gamma radiation is excessively penetrating</li> <li>○ Long half-life of 28 years means sample can last a long time - decreases maintenance costs and increasing convenience</li> </ul> </li> <li>• Technetium has a short half-life of 6 hours that is long enough for diagnosis to be made but not too long that the patient is unnecessarily exposed to radiation</li> </ul>

# HW ANSWERS

4.	1	Identifies Polonium-210 undergoes $\alpha$ -decay as shown: ${}_{84}^{210}\text{Po} \rightarrow {}_{82}^{206}\text{Pb} + {}_2^4\text{He} + \text{energy}$
	1	Identifies that $\alpha$ -decay cannot penetrate steel
	1	Identifies Strontium-90 undergoes $\beta$ -decay as shown: ${}_{38}^{90}\text{Sr} \rightarrow {}_{39}^{90}\text{Y} + {}_{-1}^0\beta + \text{energy}$
	1	Identifies that $\beta$ -decay can penetrate steel AND therefore should be used

5.	1	Identifies $\alpha$ -decay occurs when an overcrowded nucleus ( $z > 83$ ) disrupts the strong nuclear binding force AND a helium nucleus is emitted in the process
	1	Identifies $\beta^-$ -decay occurs when the neutron to proton ratio is too high AND explains a neutron turns into a proton and an electron - antineutrino and energy are emitted
	1	Identifies $\beta^+$ -decay occurs when the neutron to proton ratio is too low AND explains a proton turns into a neutron to emit a positron, neutrino and energy
	1	Identifies that $\gamma$ -decay may occur alongside $\alpha$ -decay or $\beta$ -decay or in a metastable nucleus
	2	Provides correct equation for ALL 4 types of decay <i>Deduct 1 mark for any inaccuracies or missing equations</i>

